

HOME ELEVATORS

Home Elevators

Luxury and convenience in your home

mitsubishi electric building solutions corporation

HEAD OFFICE: TOKYO BLDG., 2-7-3, MARUNOUCHI, CHIYODA-KU, TOKYO 100-8310, JAPAN

<https://www.MEBS.com/>

Japan Quality (Advanced Design)

Our home elevators developed in Japan are designed to fit into your home and villas, to add value with a wide range of advanced design.

Space-Saving

Our Machine-Room-Less design offers minimal overhead, pit depth and shaft dimension.

Single-Phase Power Supply Design

Operating on Single-phase 210-240V which is commonly available in your home and villas.

Earthquake-Resistant Design

Our home elevators complying with The Building Standard Law of Japan conform to the strength section of Japan Earthquake-Resistant standard.

User-Friendly

Our home elevators are designed to ensure the safety and comfort for all people: Providing automatic doors and multi-beam door sensors as standard on all models helps older people and people with disabilities use our home elevator more safely and comfortably.

More Comfort Atmosphere

As our home elevators apply rope type, less odors and no worry for oil leakages which may happen with hydraulic lifts.

Energy-Saving (ECO-Friendly)

The car lighting and electric fan are automatically turned off and standby power is significantly reduced (ECO Mode).

In addition, LED lighting and high efficiently transformer are applied as standard.

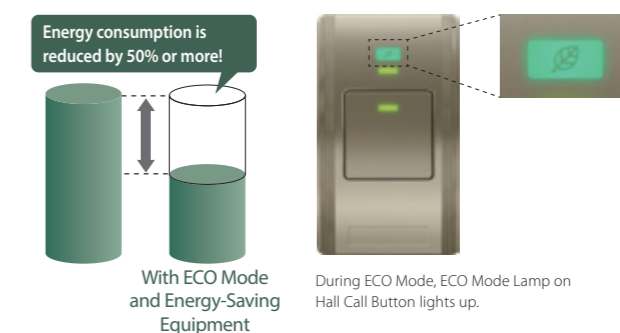

CONTENTS

Japan Quality (Advanced Design)	P2
Safety	P3
Comfort	P4
Lineup	P5
Glass Car Design	P7
Deluxe Car Design	P11
Standard Car Design	P13
Large-Depth Car Design	P17
Appearance	P19
Plan View	P21
Specifications	P22



Safety Features

Our home elevators are always provided with a wide range of safety features also found in commercial elevators.

Mitsubishi Emergency Landing Device Standard

Upon electric power supply failure, by using a rechargeable battery, a car automatically moves to the nearest lower floor (Standard) or bottom floor (Optional) and doors open for the safe evacuation of passengers.

Multi-Beam Door Sensor Standard

Multiple infrared light beams cover the door height range of 10mm to 1580mm from the floor level to detect passengers or objects. When any of the beams are blocked, the closing doors immediately reverse to re-open safely.

Modular Jack (for Landline Phone) Standard

Modular Jack is provided in the car for easy installation of a landline phone (provided by customers) that enables passengers to notify or communicate directly with outside.

*It is highly recommended to provide the landline phone in the car to call for help in case of emergency.
 *Instead of providing the landline phone, a mobile phone can be kept in the car all the time because USB Power Supply enables the mobile phone to be charged.
 *Make sure that outside call over the landline phone or mobile phone is working in advance.

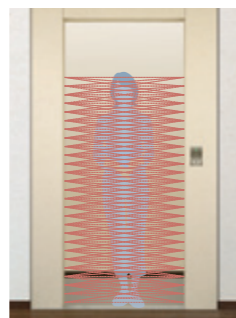

This image is for the illustrative purposes only

Comfort features

Our home elevators offer a wide range of comfort features for your home and villas.

Extending Door Opening Time Standard

Door opening time can be extended by 3 minutes by pressing Door Open Button on Car Operating Panel or Hall Call Button while the doors are open.

USB Power Supply (Type-A/DC5V 2.4A) Standard

USB charging port can be used for various purposes (such as fan, aroma diffuser and air cleaners provided by Customers)



Management Key Switch Standard

Management Key Switch installed at bottom floor deactivates the elevator.

For example, owner can take the elevator out of service manually with this switch before leaving the house to prevent children from playing with the elevator.

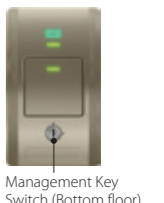

One Additional Management Key Switch Optional

One Additional Management Key Switch can be applied at any floor other than bottom floor. For example, if Management Key Switch is applied at ground floor (main entrance) and basement floor (garage), owner can more conveniently switch to disable/able the elevator.



Specifications are subject to change without notice.
 Actual color may differ slightly from those shown.

Lineup

	Glass Car Design		Deluxe Car Design		Standard Car Design			Large-Depth Car Design
	SVC260G	SHA240G	SVC260D	SVC200D	SHA300S	SVC280S	SVC200S	SVC260SL
Rated Capacity	260Kg	240kg	260kg	200kg	300kg	280kg	200kg	260kg
Persons	4	3	4	3	4	4	3	4
Door Type	4-Panel Center Opening	2-Panel Center Opening	4-Panel Center Opening		2-Panel Center Opening	4-Panel Center Opening		4-Panel Center Opening
Car								
								
Rated Speed	Up 20m/min, Down 30m/min				Up 20m/min, Down 30m/min			
Max. Stops	5				5			
Max. Travel (m)		13		13				
		-		10	-		10	-
Car Size (mm)	(W)950 x (D)1150 x (H)2100		(W)950 x (D)1150 x (H)2000*1		(W)950 x (D)1150 x (H)2000*1			(W)880 x (D)1300 x (H)2000*1
Door Opening Size (mm)	(W)800 x (H)2000		(W)800 x (H)1900*2		(W)800 x (H)1900*2			

*1 Optional: (H)2100mm *2 Optional: (H)2000mm
Please see page 21 for more details

Specifications are subject to change without notice.
Actual color may differ slightly from those shown.

Glass Car Design (For Indoor / Outdoor Enclosed)

Access Here for Design Simulator
Design Simulator enables to visualize
the car and entrance design.



Car Design

SVC260G
4 Persons / 260Kg



- Ceiling** LED Down Light
Type: SUS-HL
- Side Walls,
Front Return &
Transom Panel** SUS-HL
- Car Doors** SUS-HL
- Windows** Triple Slit Transparent
Glass (Optional)
- Floor** F-33(Optional)
- Handrail** Rear side Handrail
(Stainless Steel)
- Telephone** Provided by
Customers

Entrance Design



- Entrance Doors / Frame** SUS-HL
(Optional)
- Windows** Triple slit Transparent Glass
(Optional)

Basic Specifications

		SVC260G
Rated Capacity		4 Persons / 260kg
Rated Speed		Up 20m/min, Down 30m/min
Max. Stops		5
Max. Travel	1-Gate	13m
	2-Gate	-
Driving System		Basement Drum Type
Control System		VVF Inverter Drive
Power Supply		Single-Phase 210V•220V•230V•240V 2-Wired
Door Type		4-Panel Center Opening
Starting Frequency		150 times/day

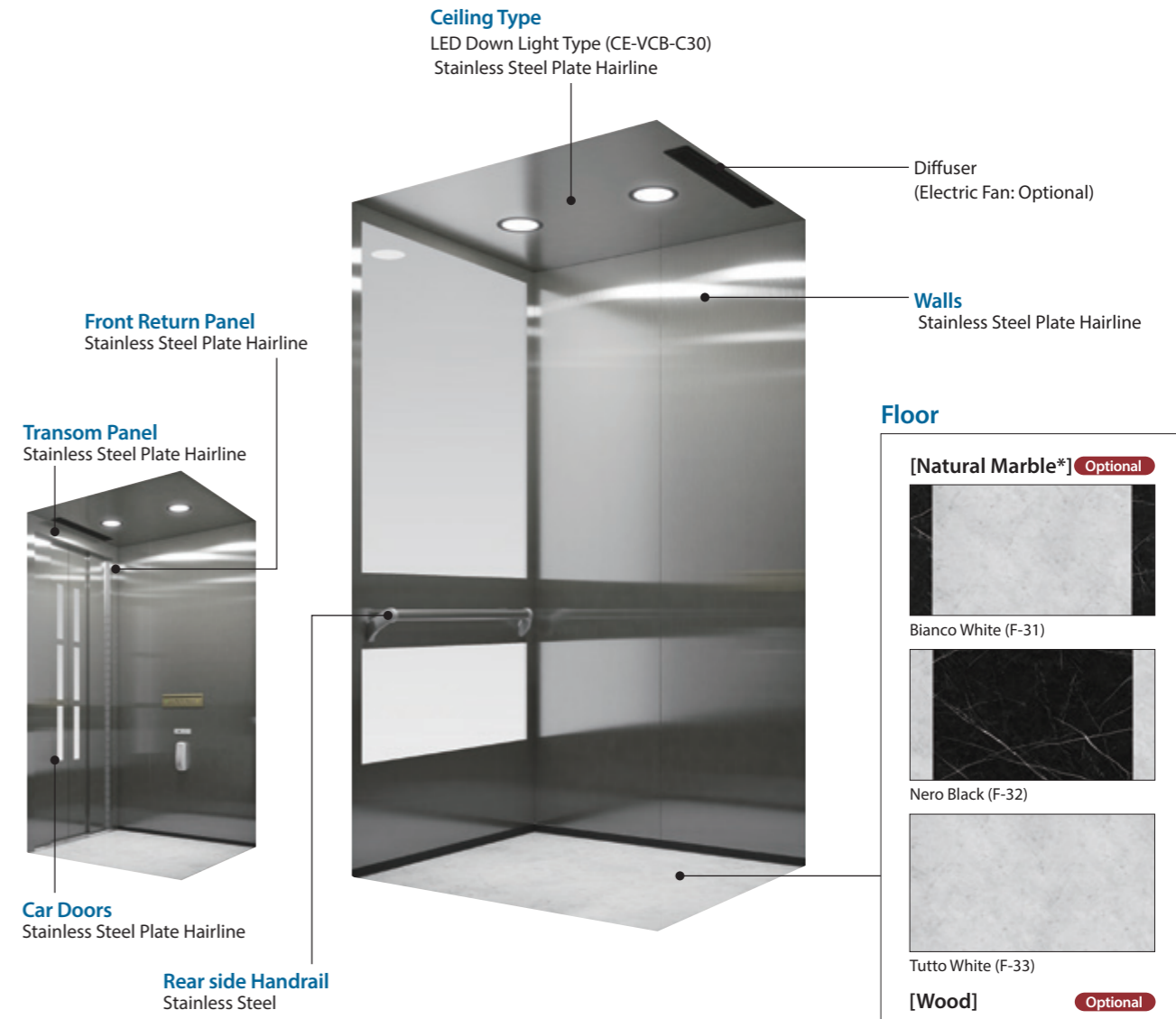

Entrance Doors / Entrance Door Frame

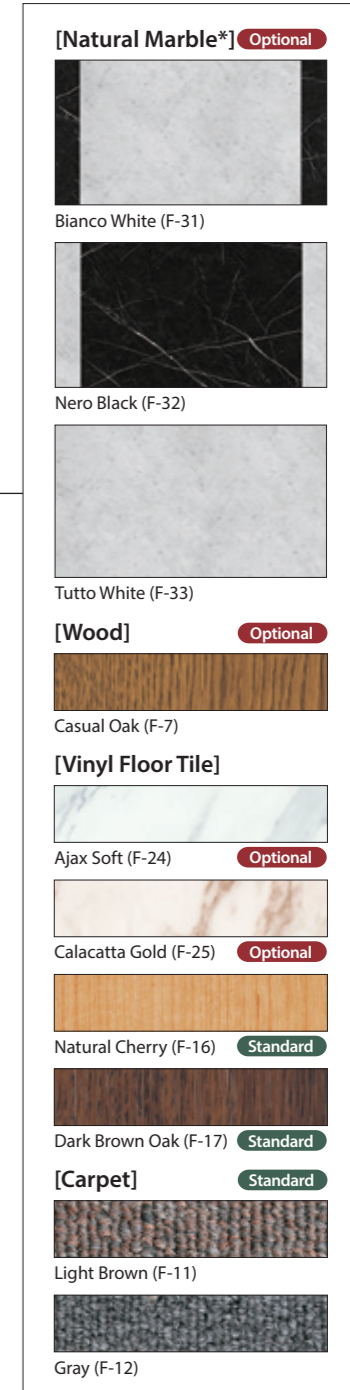
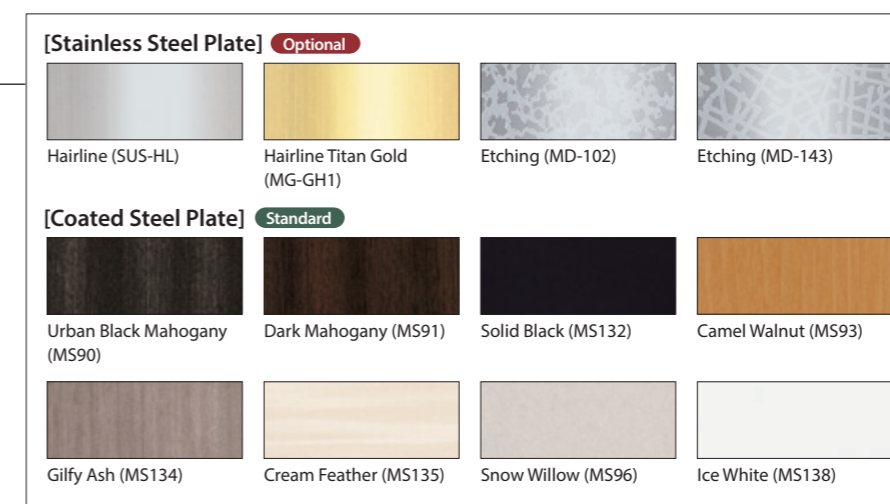

*The pattern is different individually due to the natural stone.

Specifications are subject to change without notice.
Actual color may differ slightly from those shown.

Glass Car Design (For Indoor / Outdoor Enclosed)

Access Here for Design Simulator
Design Simulator enables to visualize
the car and entrance design.



Car Design

SHA240G
3 Persons / 240Kg



- Ceiling** LED Down Light
Type: SUS-HL
- Side Walls,
Front Return &
Transom Panel** SUS-HL
- Car Doors** SUS-HL
- Windows** Large Transparent
Glass (Optional)
- Floor** F-32 (Optional)
- Handrail** 3 side Handrails
(Stainless Steel)
- Telephone** Provided by
Customers

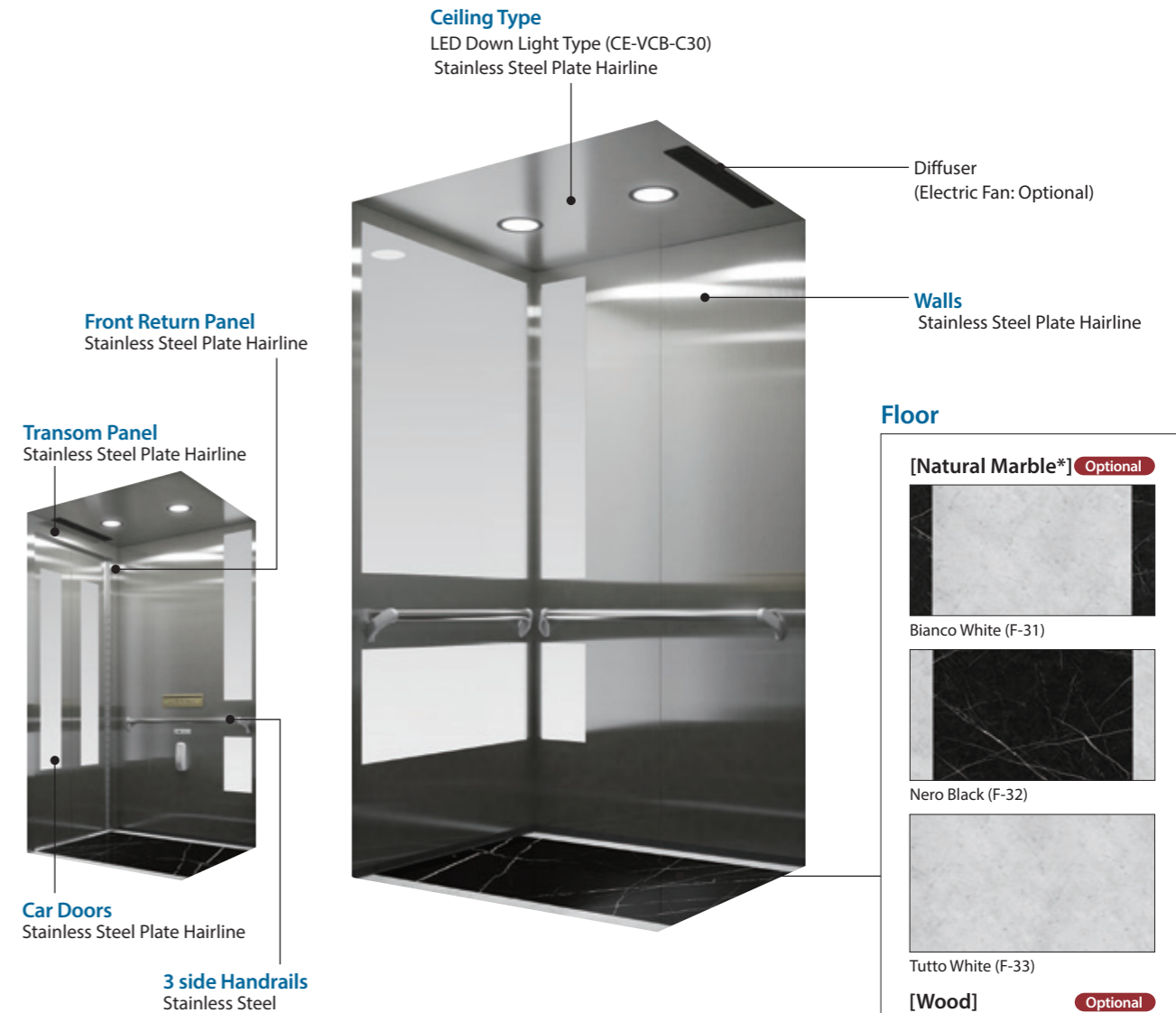

- [Natural Marble*] Optional**
- Bianco White (F-31)
- Nero Black (F-32)
- Tutto White (F-33)
- [Wood] Optional**
- Casual Oak (F-7)
- [Vinyl Floor Tile]**
- Ajax Soft (F-24) **Optional**
- Calacatta Gold (F-25) **Optional**
- Natural Cherry (F-16) **Standard**
- Dark Brown Oak (F-17) **Standard**
- [Carpet] Standard**
- Light Brown (F-11)
- Gray (F-12)

Basic Specifications

		SHA240G
Rated Capacity		3 Persons / 240kg
Rated Speed		Up 20m/min, Down 30m/min
Max. Stops		5
Max. Travel	1-Gate	13m
	2-Gate	-
Driving System		Basement Drum Type
Control System		VVF Inverter Drive
Power Supply		Single-Phase 210V•220V•230V•240V 2-Wired
Door Type		2-Panel Center Opening
Starting Frequency		150 times/day

Entrance Design



- Entrance Doors / Frame** SUS-HL
(Optional)
- Windows** Large Transparent Glass
(Optional)

Entrance Doors / Entrance Door Frame

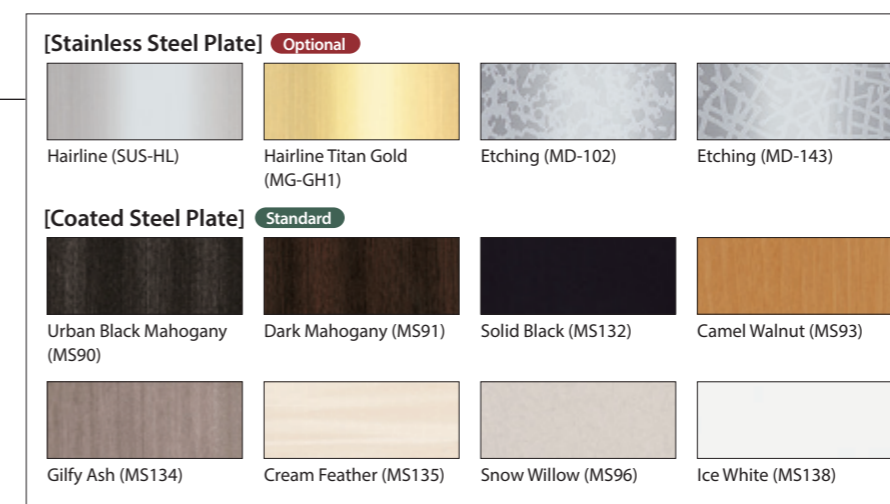

*The pattern is different individually due to the natural stone.

Specifications are subject to change without notice.
Actual color may differ slightly from those shown.

Deluxe Car Design

Access Here for Design Simulator
Design Simulator enables to visualize
the car and entrance design.



Car Design



SVC260D
4 Persons / 260kg



SVC200D
3 Persons / 200kg



- Ceiling** LED Full Ceiling Light Type
- Stainless Mirror** MR-VCB-NN0-ST (Optional)
- Side Walls** MS96
- Bottom Wall of Car Operating Panel** MS90
- Front Return & Transom Panel** MS96
- Car Doors** MS96
- Windows** Double Slit Gray Smoked Plastic
- Floor** F-31 (Optional)
- Handrail (Optional)** Black Wood
- Telephone** Provided by Customers

Basic Specifications

	SVC260D	SVC200D
Rated Capacity	4 Persons / 260kg	3 Persons / 200kg
Rated Speed	Up 20m/min, Down 30m/min	
Max. Stops	5	
Max. Travel	1-Gate	13m
	2-Gate	10m
Driving System	Basement Drum Type	
Control System	VVVF Inverter Drive	
Power Supply	Single-Phase 210V•220V•230V•240V 2-Wired	
Door Type	4-Panel Center Opening	
Starting Frequency	150 times/day	

Car Design Example



- Ceiling** LED Full Ceiling Light Type
- Stainless Mirror** MR-VCB-NN0-SN
- Rear Wall** MS138
- Side Walls** MS138
- Bottom Wall of Car Operating Panel** MS138
- Floor** F-31 (Optional)
- Handrail (Optional)** Black Wood
- Telephone** Provided by Customers



- Ceiling** LED Down Light Type: MS96
- Stainless Mirror** MR-VCB-NN0-ST (Optional)
- Rear Wall** MS96
- Side Walls** MS90
- Bottom Wall of Car Operating Panel** MS90
- Floor** F-32 (Optional)
- Handrail (Optional)** Black Wood
- Telephone** Provided by Customers

Entrance Design



- Entrance Doors / Frame** MS135
- Windows** Double Slit Transparent Glass (Optional)

Ceiling / Rear Wall / Side Walls / Bottom Wall of Car Operating Panel / Front Return & Transom Panel

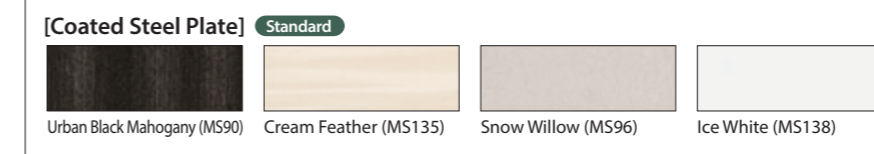

Stainless Mirror

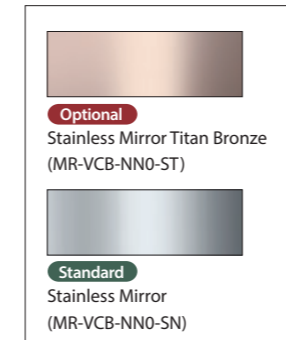

Car Doors / Entrance Doors / Entrance Door Frame

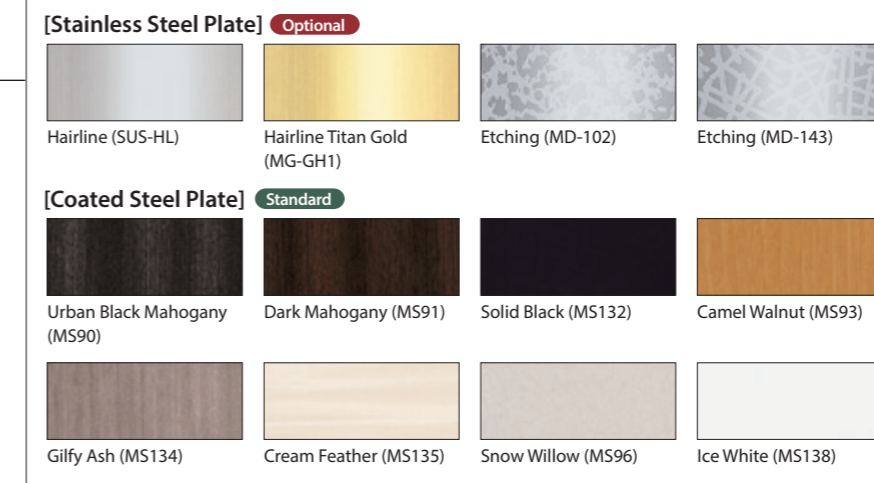

Ceiling Type

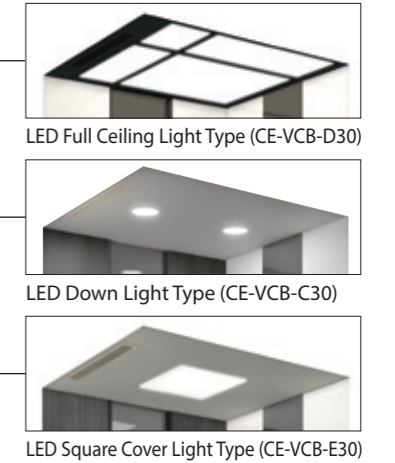

Floor

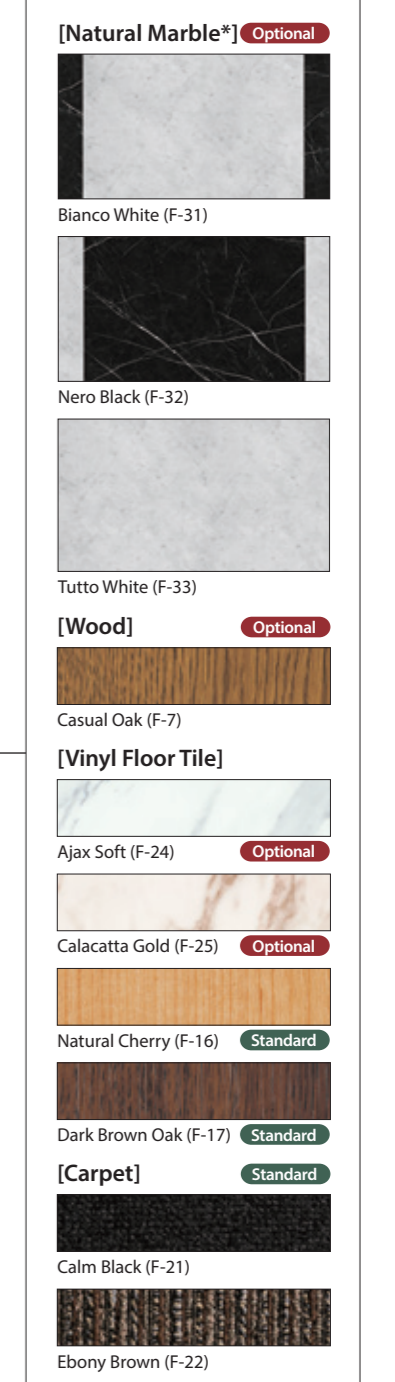

*The pattern is different individually due to the natural stone. Not applicable to 2-Gate Model.

Specifications are subject to change without notice.
Actual color may differ slightly from those shown.

Standard Car Design

Car Design

Access Here for Design Simulator
Design Simulator enables to visualize
the car and entrance design.



SHA300S
4 Persons / 300kg



- Ceiling** LED Down Light Type: MS96
- Side Walls, Front Return & Transom Panel** MS96
- Car Doors** MS96
- Windows** Large Transparent Glass (Optional)
- Floor** F-31 (Optional)
- Handrail (Optional)** Black Wood
- Telephone** Provided by Customers

Basic Specifications

		SHA300S
Rated Capacity		4 Persons / 300kg
Rated Speed		Up 20m/min, Down 30m/min
Max. Stops		5
Max. Travel	1-Gate	13m
	2-Gate	-
Driving System		Basement Drum Type
Control System		VVF Inverter Drive
Power Supply		Single-Phase 210V•220V•230V•240V 2-Wired
Door Type		2-Panel Center Opening
Starting Frequency		150 times/day

Car Design Example



- Ceiling** LED Down Light Type: SUS-HL (Optional)
- Rear Wall** MR-VCB-NN0-SN (Optional)
- Side Walls** SUS-HL (Optional)
- Floor** F-12
- Handrail (Optional)** Stainless Steel
- Telephone** Provided by Customers



- Ceiling** LED Rectangle Cover Light Type: MS135
- Rear Wall** MS135
- Side Walls** MS135
- Floor** F-17
- Handrail (Optional)** Black Wood
- Mirror (Optional)** Aluminium Frame
- Telephone** Provided by Customers

Entrance Design



- Entrance Doors / Frame** SUS-HL (Optional)
- Windows** Large Transparent Glass (Optional)

Ceiling / Rear Wall / Side Walls, Front Return & Transom Panel

[Stainless Steel Plate] Optional

Hairline (SUS-HL)

[Coated Steel Plate] Standard

Urban Black Mahogany (MS90) Cream Feather (MS135) Snow Willow (MS96) Ice White (MS138)

[Stainless Mirror] (Rear Wall only) Optional

Stainless Mirror (MR-VCB-NN0-SN) Stainless Mirror Titan Gold (MR-VCB-NN0-SG)



Car Doors / Entrance Doors / Entrance Door Frame

[Stainless Steel Plate] Optional

Hairline (SUS-HL) Hairline Titan Gold (MG-GH1) Etching (MD-102) Etching (MD-143)

[Coated Steel Plate] Standard

Urban Black Mahogany (MS90) Dark Mahogany (MS91) Solid Black (MS132) Camel Walnut (MS93)

Gilfy Ash (MS134) Cream Feather (MS135) Snow Willow (MS96) Ice White (MS138)

Ceiling Type



Floor

[Natural Marble*] Optional

Bianco White (F-31)

Nero Black (F-32)

Tutto White (F-33)

[Wood] Optional

Casual Oak (F-7)

[Vinyl Floor Tile]

Ajax Soft (F-24) Optional

Calacatta Gold (F-25) Optional

Natural Cherry (F-16) Standard

Dark Brown Oak (F-17) Standard

[Carpet] Standard

Light Brown (F-11)

Gray (F-12)

*The pattern is different individually due to the natural stone.

Specifications are subject to change without notice.
Actual color may differ slightly from those shown.

Standard Car Design

Car Design

Access Here for Design Simulator
Design Simulator enables to visualize
the car and entrance design.



SVC280S
4 Persons / 280kg



SVC200S
3 Persons / 200kg



Car Design Example



- Ceiling** LED Down Light Type: MS96
- Rear Wall** MS96
- Side Walls** MS96
- Floor** F-24 (Optional)
- Handrail (Optional)** Stainless Steel
- Mirror (Optional)** Aluminium Frame
- Telephone** Provided by Customers



- Ceiling** LED Rectangle Cover Light Type: MS138
- Rear Wall** MR-VCB-NN0-SG (Optional)
- Side Walls** MS90
- Floor** F-31 (Optional)
- Handrail (Optional)** Black Wood
- Telephone** Provided by Customers

- Ceiling** LED Down Light Type: SUS-HL (Optional)
- Side Walls, Front Return & Transom Panel** SUS-HL (Optional)
- Car Doors** SUS-HL (Optional)
- Windows** Double Slit Gray Smoked Plastic
- Floor** F-32 (Optional)
- Handrail (Optional)** Stainless Steel
- Telephone** Provided by Customers

Basic Specifications

	SVC280S	SVC200S
Rated Capacity	4 Persons / 280kg	3 Persons / 200kg
Rated Speed	Up 20m/min, Down 30m/min	
Max. Stops	5	
Max. Travel	1-Gate	13m
	2-Gate	10m
Driving System	Basement Drum Type	
Control System	VVVF Inverter Drive	
Power Supply	Single-Phase 210V•220V•230V•240V 2-Wired	
Door Type	4-Panel Center Opening	
Starting Frequency	150 times/day	

Entrance Design



- Entrance Doors / Frame** MS134
- Windows** Double Slit Transparent Glass (Optional)

Ceiling / Rear Wall / Side Walls, Front Return & Transom Panel

[Stainless Steel Plate] Optional

Hairline (SUS-HL)

[Coated Steel Plate] Standard

Urban Black Mahogany (MS90) Cream Feather (MS135) Snow Willow (MS96) Ice White (MS138)

[Stainless Mirror] (Rear Wall only) Optional

Stainless Mirror (MR-VCB-NN0-SN) Stainless Mirror Titan Gold (MR-VCB-NN0-SG)



Ceiling Type

LED Down Light Type (CE-VCB-C30)

LED Rectangle Cover Light Type (CE-VCB-A30)

Diffuser (Electric Fan: Optional)

Floor

[Natural Marble*] Optional

Bianco White (F-31)

Nero Black (F-32)

Tutto White (F-33)

[Wood] Optional

Casual Oak (F-7)

[Vinyl Floor Tile]

Ajax Soft (F-24) Optional

Calacatta Gold (F-25) Optional

Natural Cherry (F-16) Standard

Dark Brown Oak (F-17) Standard

[Carpet] Standard

Light Brown (F-11)

Gray (F-12)

Car Doors / Entrance Doors / Entrance Door Frame

[Stainless Steel Plate] Optional

Hairline (SUS-HL) Hairline Titan Gold (MG-GH1) Etching (MD-102) Etching (MD-143)

[Coated Steel Plate] Standard

Urban Black Mahogany (MS90) Dark Mahogany (MS91) Solid Black (MS132) Camel Walnut (MS93)

Gilfy Ash (MS134) Cream Feather (MS135) Snow Willow (MS96) Ice White (MS138)

*The pattern is different individually due to the natural stone. Not applicable to 2-Gate Model.

Specifications are subject to change without notice. Actual color may differ slightly from those shown.

Large-Depth Car Design

Car Design

Access Here for Design Simulator
Design Simulator enables to visualize
the car and entrance design.



SVC260SL
4 Persons / 260kg



Large-Depth Type

- Ceiling** LED Rectangle Cover Light Type: MS138
- Side Walls, Front Return & Transom Panel** MS138
- Car Doors** MS138
- Windows** Double Slit Gray Smoked Plastic
- Floor** F-12
- Handrail (Optional)** Black Wood
- Telephone** Provided by Customers

Basic Specifications

		SVC260SL
Rated Capacity		4 Persons / 260kg
Rated Speed		Up 20m/min, Down 30m/min
Max. Stops		5
Max. Travel	1-Gate	13m
	2-Gate	-
Driving System		Basement Drum Type
Control System		VVF Inverter Drive
Power Supply		Single-Phase 210V•220V•230V•240V 2-Wired
Door Type		4-Panel Center Opening
Starting Frequency		150 times/day

Car Design Example



- Ceiling** LED Down Light Type: MS90
- Rear Wall** MS90
- Side Walls** MS90
- Floor** F-7 (Optional)
- Handrail (Optional)** Beige Wood
- Mirror (Optional)** Aluminium Frame
- Telephone** Provided by Customers



- Ceiling** LED Rectangle Cover Light Type: MS135
- Rear Wall** MR-VCB-NN0-SN (Optional)
- Side Walls** MS135
- Floor** F-11
- Handrail (Optional)** Stainless Steel
- Telephone** Provided by Customers

Entrance Design



- Entrance Doors / Frame** MS91
- Windows** Triple Slit Transparent Glass (Optional)

Ceiling / Rear Wall / Side Walls, Front Return & Transom Panel

[Stainless Steel Plate] Optional

Hairline (SUS-HL)

[Coated Steel Plate] Standard

Urban Black Mahogany (MS90) Cream Feather (MS135) Snow Willow (MS96) Ice White (MS138)

[Stainless Mirror] (Rear Wall only) Optional

Stainless Mirror (MR-VCB-NN0-SN) Stainless Mirror Titan Gold (MR-VCB-NN0-SG)

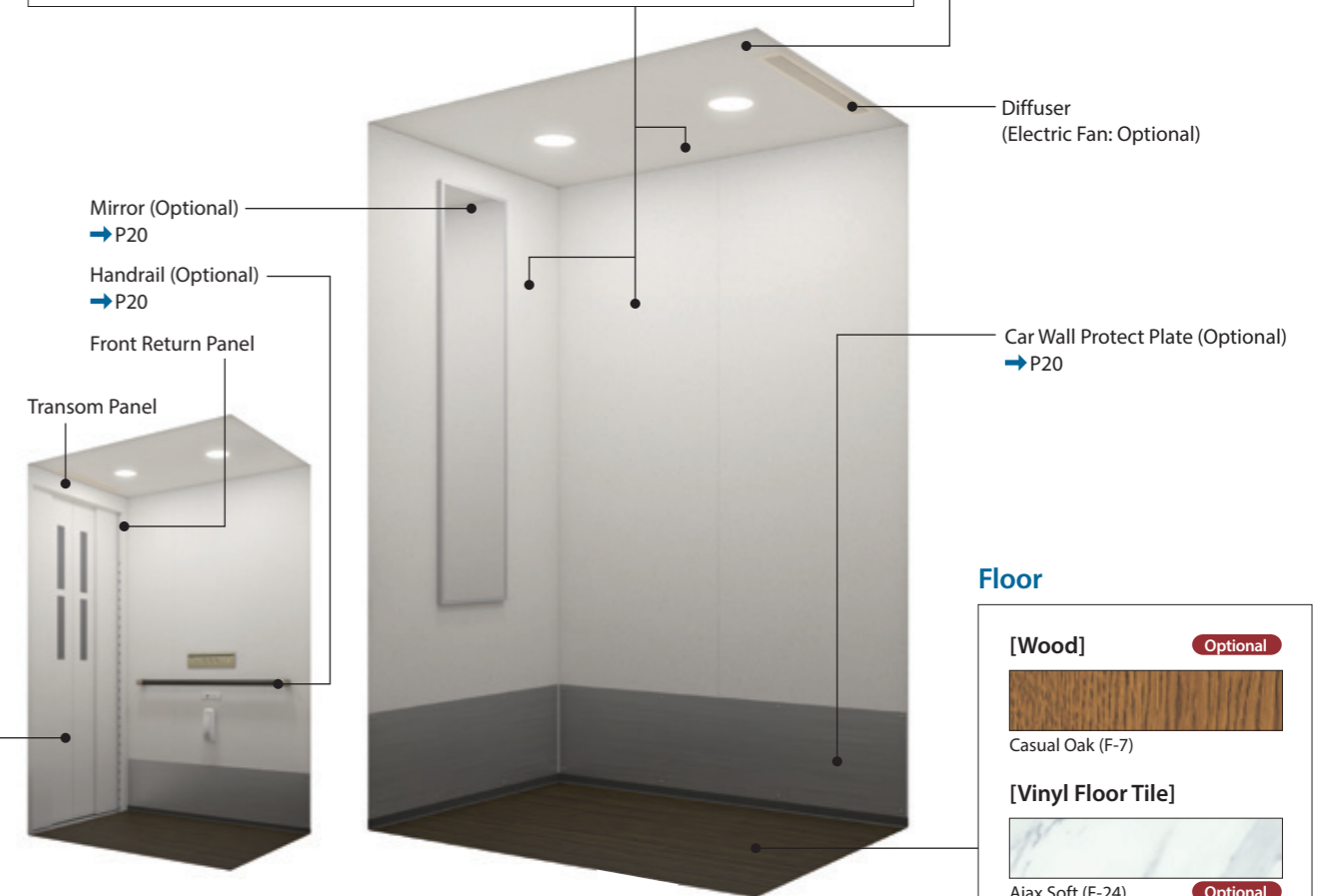

- Mirror (Optional) → P20
- Handrail (Optional) → P20
- Front Return Panel
- Transom Panel

Ceiling Type



LED Rectangle Cover Light Type (CE-VCB-A30)

Diffuser (Electric Fan: Optional)

Car Wall Protect Plate (Optional) → P20

Floor

[Wood] Optional

Casual Oak (F-7)

[Vinyl Floor Tile]

Ajax Soft (F-24) Optional

Calacatta Gold (F-25) Optional

Natural Cherry (F-16) Standard

Dark Brown Oak (F-17) Standard

[Carpet] Standard

Light Brown (F-11)

Gray (F-12)

* Natural Marble is not applicable to SVC260SL.

Car Doors / Entrance Doors / Entrance Door Frame

[Stainless Steel Plate] Optional

Hairline (SUS-HL) Hairline Titan Gold (MG-GH1) Etching (MD-102) Etching (MD-143)

[Coated Steel Plate] Standard

Urban Black Mahogany (MS90) Dark Mahogany (MS91) Solid Black (MS132) Camel Walnut (MS93)

Gilfy Ash (MS134) Cream Feather (MS135) Snow Willow (MS96) Ice White (MS138)

Specifications are subject to change without notice.
Actual color may differ slightly from those shown.

Appearances

Car and Entrance Door Windows

2-Panel Center Opening Door (SHA240G/SHA300S)

[Window Type]

Large Transparent Glass **Optional**



No Window **Standard**



4-Panel Center Opening Door (SVC260G/SVC260D/SVC200D/SVC280S/SVC200S/SVC260SL)

[Window Shape]

Triple Slit* **Optional**



Double Slit **Standard**



No Window **Standard**



*When 100mm Higher Car Ceiling Height & Entrance Height is applied, Triple Slit is applied as standard.
*Triple slit is applied as standard for SVC260G

[Window Material]

Transparent Glass **Optional**

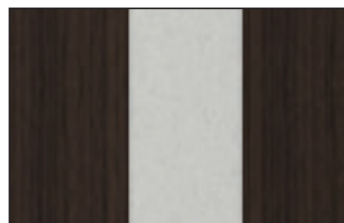

Gray Smoked Plastic **Standard**



Handrails **Optional**



Beige Wood (HR-RJ0-S30W)



Black Wood (HR-RJ0-S30B)



Stainless Steel (HR-EB0-S30S)

Mirrors **Optional**



Aluminium Frame
(MR-ED0-AN0-LGN)

Car Wall Protect Plate **Optional**



Signalization

Car Operating Panel **Standard**



Door Open Button

Emergency Bell Button

Message Lamp

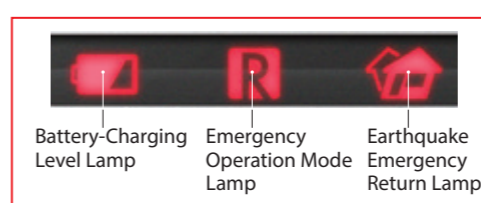

*This lamp lights up only when Earthquake Emergency Return with P-Wave Sensor (Optional) is applied.

Hall Call Button **Standard**

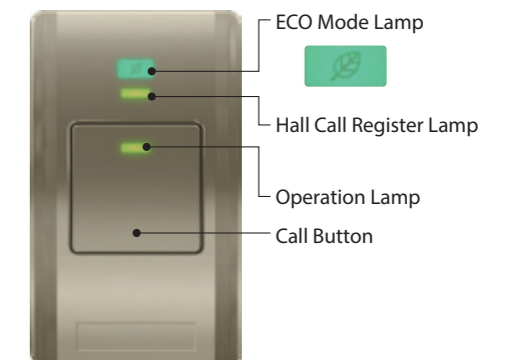

Plan View

Shaft Plan

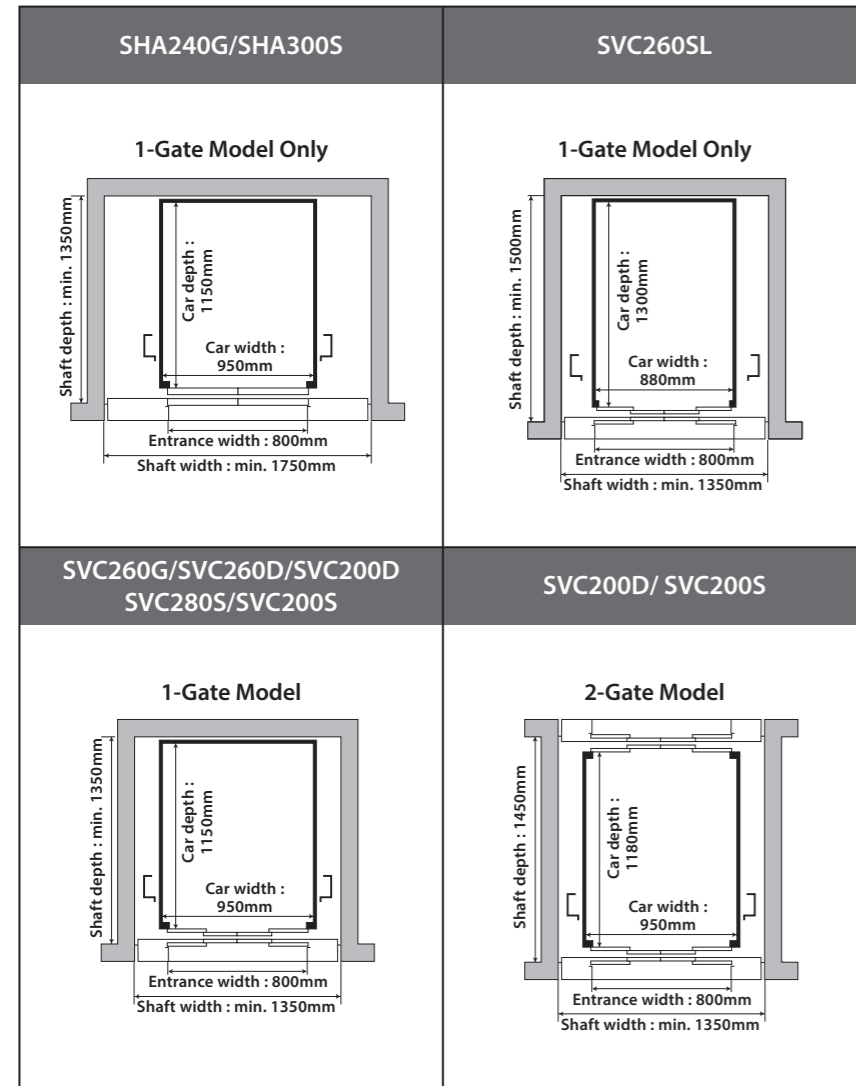

Elevation Plan

[All Models]

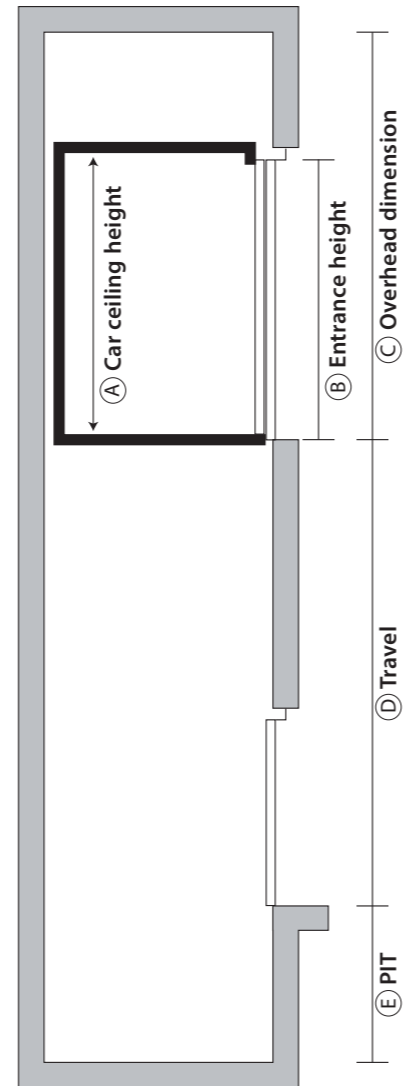

(mm)

Item	Glass Car Design		Deluxe Car Design		Standard Car Design			Large-Depth Car Design
	SVC260G	SHA240G	SVC260D	SVC200D	SHA300S	SVC280S	SVC200S	SVC260SL
(A) Car ceiling height	2100		2000/2100 (*)					
(B) Entrance height	2000		1900/2000 (*)					
(C) Min. Overhead dimension	2500		2450/2550 (*)		2400/2500 (*)			
(D) Max. Travel	1Gate Model	13000						
	2Gate Model	-	-	10000	-	-	10000	-
(E) Min. PIT	1Gate Model	560/610 (**)						
	2Gate Model	-	-	760/800 (**)	-	-	760/800 (**)	-

*1 When 100mm Higher Car Ceiling Height & Entrance Height (Optional) is applied
*2 When Double Isolation Unit for Absorbing Vibration and Sound (Optional) is applied

Specifications

●Standard ○Optional - Not applicable

Item	Glass Car Design		Deluxe Car Design		Standard Car Design			Large-Depth Car Design
	SVC260G	SHA240G	SVC260D	SVC200D	SHA300S	SVC280S	SVC200S	SVC260SL
Safety Feature	Multi-Beam Door Sensor	●	●	●	●	●	●	●
	Door Load Detector (DLD)	●	●	●	●	●	●	●
	Safe Landing (SFL)	●	●	●	●	●	●	●
	Next Landing (NXL)	●	●	●	●	●	●	●
	Overload Holding Stop (OLH)	●	●	●	●	●	●	●
	Mitsubishi Emergency Landing Device (MELD) Landing on Nearest Lower Floor	●	●	●	●	●	●	●
	Mitsubishi Emergency Landing Device (MELD) Landing on Bottom Floor	○	○	○	○	○	○	○
	Emergency Car Lighting	●	●	●	●	●	●	●
	Emergency Bell Button	●	●	●	●	●	●	●
	Unintended Car Movement Protection System	●	●	●	●	●	●	●
Energy-Saving	ECO Mode	●	●	●	●	●	●	●
Car Design	Handrail (Wood / Stainless Steel)	● ^{*4}	● ^{*5}	○	○	○	○	○
	Mirror (Aluminium Frame)	-	-	-	-	○	○	○
	Electric Fan	○	○	●	●	○	○	○
	Car Wall Protect Plate	○	○	-	-	○	○	○
	Stainless Steel Plate (Ceiling / Wall / Front Return & Transom Panel)	●	●	-	-	○	○	○
	Stainless Steel Plate (Car Doors)	●	●	○	○	○	○	○
	Stainless Mirror (at Whole Rear Wall)	-	-	-	-	○	○	○
	Stainless Mirror Titan Gold (at Whole Rear Wall)	-	-	-	-	○	○	○
	Stainless Mirror (at Center Panel of Rear Wall & at Panel above Car Operating Panel)	-	-	●	●	-	-	-
	Stainless Mirror Titan Bronze (at Center Panel of Rear Wall & at Panel above Car Operating Panel)	-	-	○	○	-	-	-
Floor	Carpet (F-11, F-12)	●	●	-	-	●	●	●
	Carpet (F-21, F-22)	-	-	●	●	-	-	-
	Vinyl Floor Tile (F-16, F-17)	●	●	●	●	●	●	●
	Vinyl Floor Tile (F-24, F-25) / Wood	○	○	○	○	○	○	○
	Natural Marble (F-31, F-32, F-33) ^{*1}	○	○	○	○	○	○	-
Comfort	2-Gate Model (Only one side opening at each floor)	-	-	-	○	-	-	-
	100mm Higher Car Ceiling Height and Entrance Height	●	●	○	○	○	○	○
Car & Entrance Door Windows	No Window	●	●	●	●	●	●	●
	Large Transparent Glass Windows	-	○	-	-	○	-	-
	Double Slit Plastic Windows	-	-	●	●	-	●	●
	Double Slit Transparent Glass Windows	-	-	○	○	-	○	○
	Triple Slit Plastic Windows ^{*2}	●	-	○	○	-	○	○
Triple Slit Transparent Glass Windows	○	-	○	○	-	○	○	
Entrance Design	Stainless Steel Plate	○	○	○	○	○	○	○
	Message Lamp (on Car Operating Panel)	●	●	●	●	●	●	●
	Modular Jack / USB Power Supply	●	●	●	●	●	●	●
	Extending Door Opening Time (3 Minutes)	●	●	●	●	●	●	●
	Management Key Switch (Bottom Floor)	●	●	●	●	●	●	●
	One Additional Management Key Switch	○	○	○	○	○	○	○
	Double Isolation Unit for Absorbing Vibration and Sound ^{*3}	○	○	○	○	○	○	○
	Earthquake Emergency Return (EER) with P-Wave Sensor	○	○	○	○ ^{*6}	○	○	○ ^{*6}
	Fire Emergency Return (FER)	○	○	○	○	○	○	○
	Flood Emergency Return	○	○	○	○	○	○	○
Car Indicator	○	○	○	○ ^{*6}	○	○	○ ^{*6}	
Hall Position Indicator	○	○	○	○	○	○	○	
Car Arrival Chime	○	○	○	○	○	○	○	
Bleep Button	○	○	○	○	○	○	○	

*1 Not applicable to 2-Gate Model.
*2 When 100mm Higher Car Ceiling Height and Entrance Height (Optional) is applied, Triple Slit Plastic Windows are applied as standard.
*3 Shall be applied for Maisonette residence.
*4 Rear side handrail (Stainless Steel) is Standard.
*5 3 side handrails (Stainless Steel) is Standard
*6 Required by Building Standard Law of Japan when travel is over 7m.

NOTE1 No fuse breaker for home elevator shall be inverter compatible model supplied by others.
NOTE2 Applicable standard: Building Standard Law of Japan for SVC200D, SVC200S
Manufacturer's Standard for SVC260G, SHA240G, SVC260D, SHA300S, SVC280S, SVC260SL

Specifications are subject to change without notice.
Actual color may differ slightly from those shown.